

winterhalter

Spare Parts List GR 64 / GR 65

Edited: 07/98
Revised: 22.02.07

Part-no.: 89003906

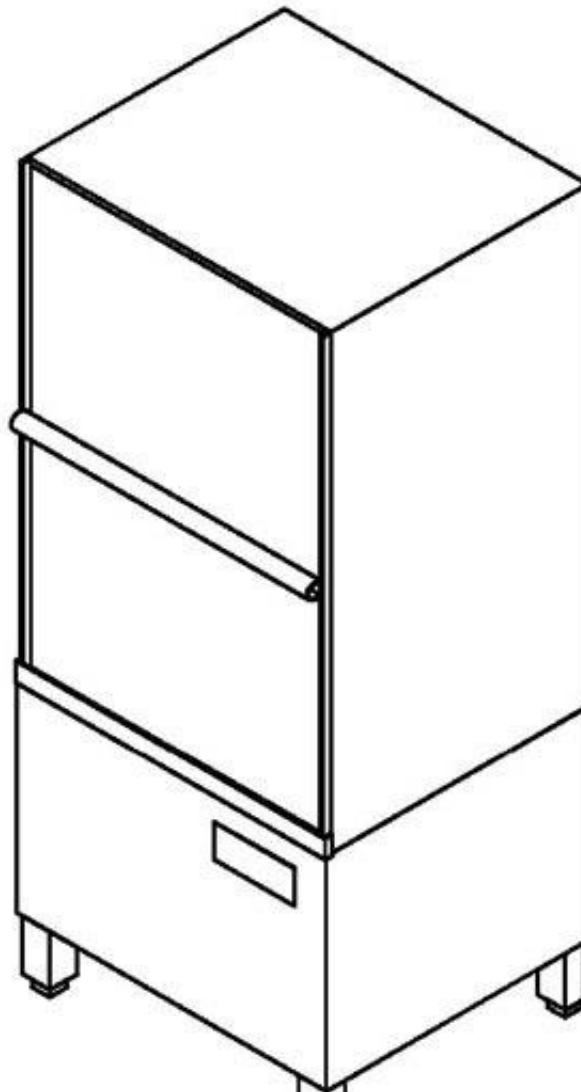

Inhaltsübersicht

Water inlet	Page 1 and 2
Tank and tank heating	Page 3 and 4
Water drain	Page 5 and 6
Mediamat	Page 7 and 8
Wash system I	Page 9 and 10
Wash system II	Page 11 and 12
Reversing	Page 13 and 14
Rinsing I	Page 15 and 16
Rinsing II (AquaMatik)	Page 17 and 18
Rinsing III	Page 19 and 20
Rinsing IV	Page 21 and 22
Dosing	Page 23 and 24
Frame, container and panels	Page 25 and 26
Door	Page 27 and 28
Electrical parts I	Page 29 and 30
Electrical parts II	Page 31 and 32
Cold water pre-rinsing (option)	Page 33 and 34

Please note the following points with regard to this list:

See separate list for racks and accessories.

Enter the required quantity in the column marked "Pc." if more than 1 part is installed and if this part is not a standard part.

GR 64 / GR 65

Wasserzulauf
Water inlet
Arrivée d'eau

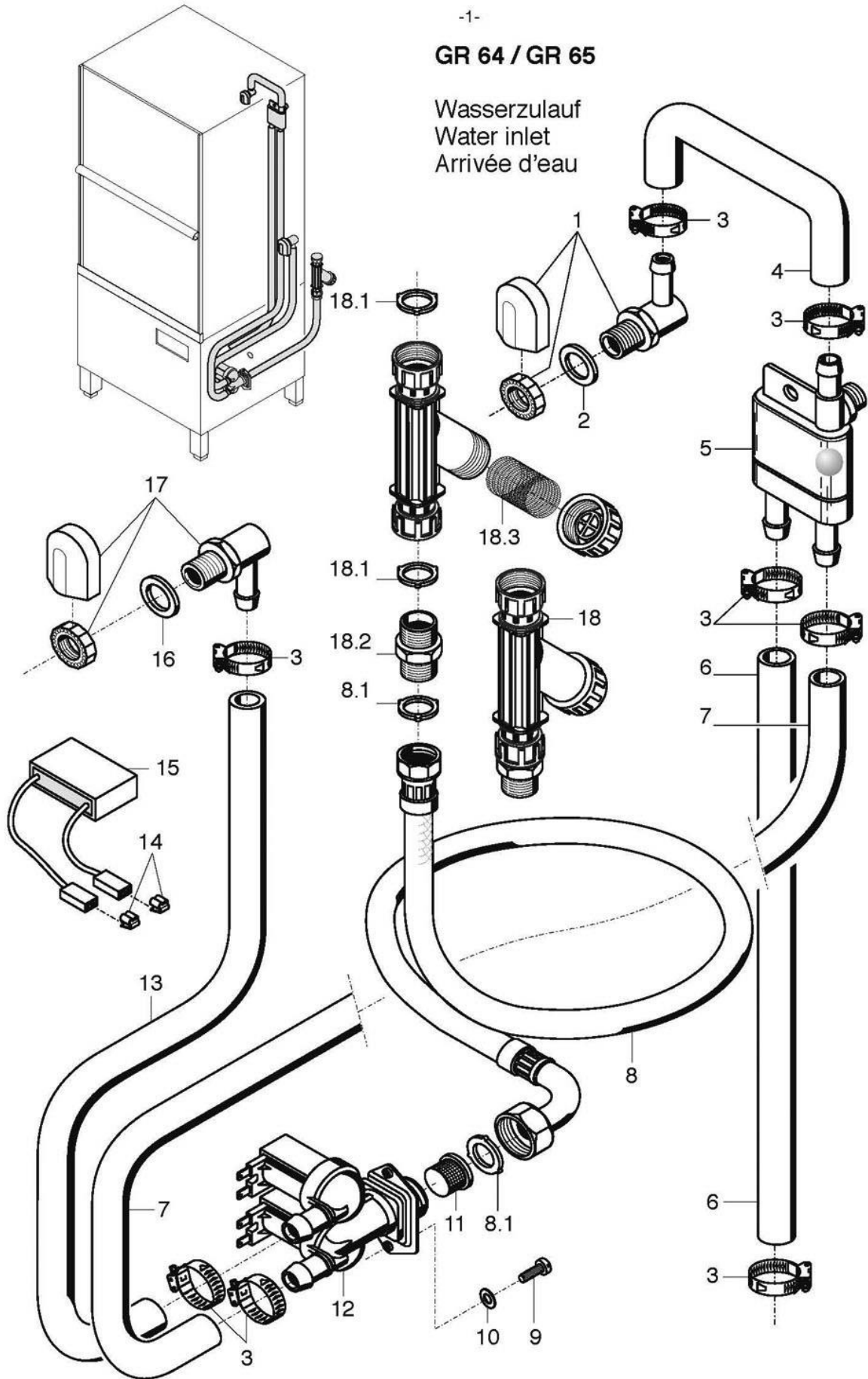

GR 64 / GR 65

Water inlet

Item	Designation	Part No.	Pc.	Notes
1	Tank inlet set (incl.item 2)	61004545		up to mach.-no.: 390 224
	Water inlet set (incl. item 16)	55 31 007		from mach.-no.: 390 225
2	Seal; \varnothing 17 x \varnothing 24 x 2,0	62001366		
3	Hose clip; \varnothing 14 - \varnothing 24	28 02 108		
4	Shaped hose; nom. dia. 13 x 4	40 03 053		from mach.-no.: 390 225
5	Backflow restrictor; lateral	35 01 194		up to mach.-no.: 390 224
	Backflow restrictor; top	35 01 193		from mach.-no.: 390 225
6	Hose; nom. dia. 13,5 x 3,5 x 1510	40 02 029		GR 64; per metre
	Hose; nom. dia. DN 13,5 x 3,5 x 1680	40 02 029		GR 65; per metre
7	Hose; nom. dia. 13,5 x 3,5 x 2030	40 02 029		GR 64; per metre
	Hose; nom. dia. 13,5 x 3,5 x 2200	40 02 029		GR 65; per metre
8	Metal hose; nom. dia. 15 x 1500; G 3/4"	29 01 303		incl. item 8.1
8.1	Seal; \varnothing 16 x \varnothing 24 x 3,0	80002241	2	
9	Pan-head screw; M 4 x 8	20 10 210		
10	Washer; \varnothing 4,3 x \varnothing 12 x 1,0	22 05 300		
11	Dirt trap	31 06 186		
12	Double solenoid valve; 220-240 V; 50/60 Hz	31 06 182		
	Double solenoid valve; 180-220 V; 50/60 Hz	31 06 200		Japan
13	Hose; nom. dia. 13,5 x 3,5 x 1600	40 02 029		per metre
14	Tab connector	31 12 018	2	only with AquaMatik; connect
15	RC element; 0,15 μ F; 3,3k Ω	31 13 114		parallel to item 12
16	Seal; \varnothing 21,5 x \varnothing 27 x 2,0	27 01 002		
17	Tank inlet set	55 31 007		incl. item 16
18	Dirt trap; kpl.	80002153		incl. item 14.1, 14.2, 14.3
18.1	Seal; \varnothing 16 x \varnothing 24 x 3,0	80002241	2	
18.2	Union stem; G 3/4" x 40; width A/F30	80002167		
18.3	Dirt trap	80002728		
o.P.	Extension hose; 1m	29 01 307		Optimal equipment
o.P.	Seal; \varnothing 16 x \varnothing 24 x 3,0	80002241		Optimal equipment

GR 64 / GR 65

Wasserablauf
Water drain
Ecoulement d'eau

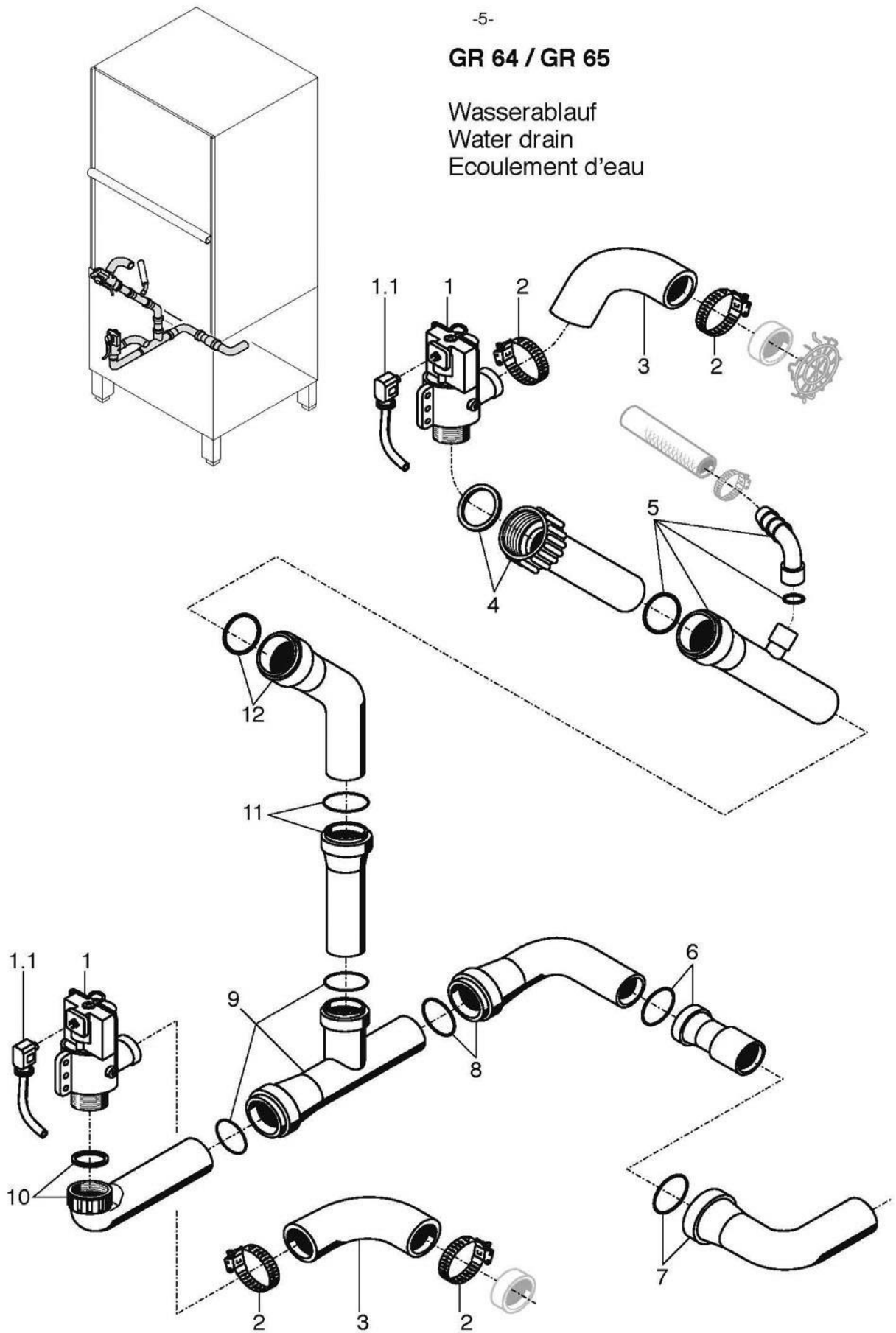

GR 64 / GR 65

Mediamat
Mediamat
Médiamat

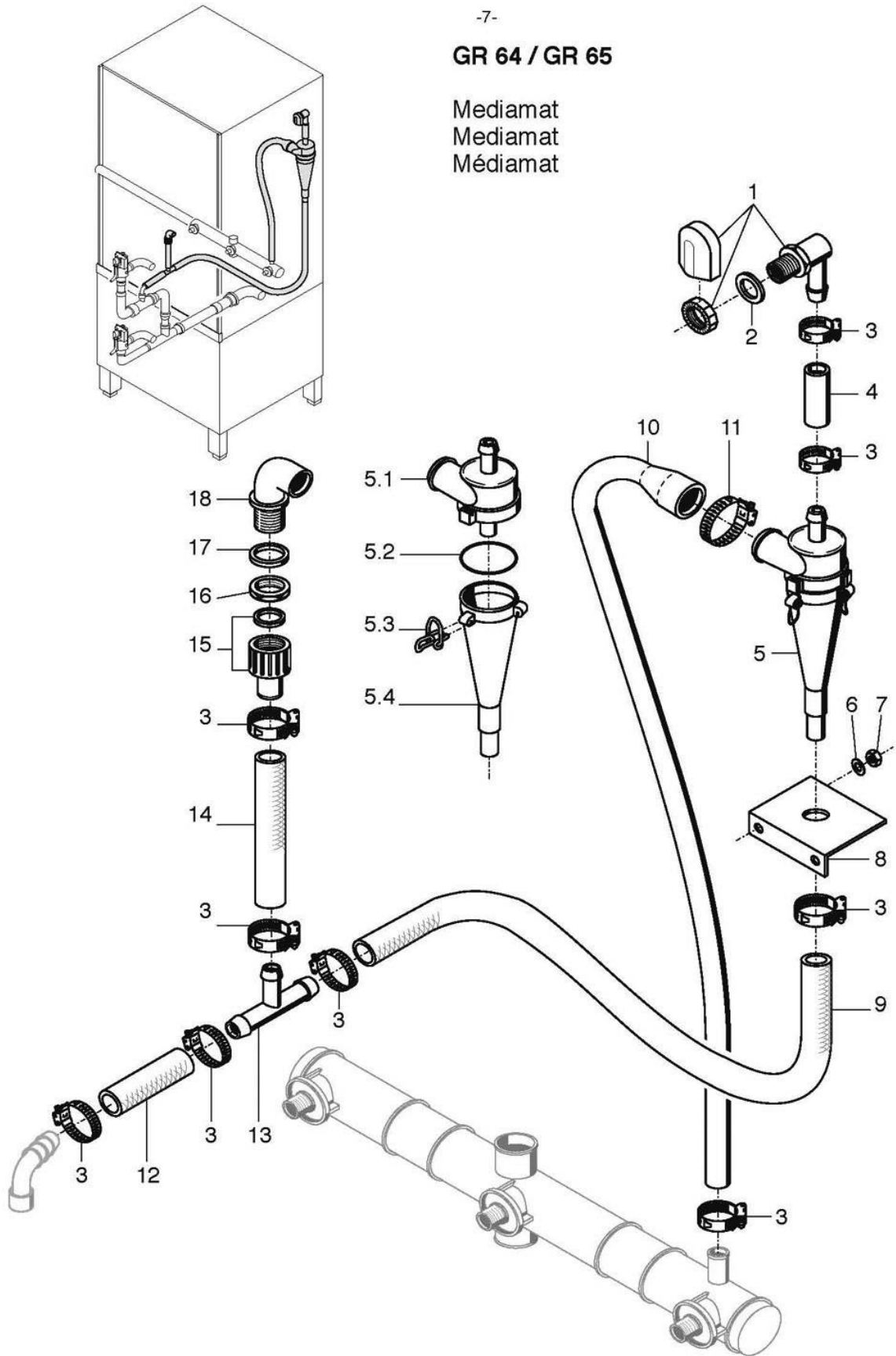

GR 64 / GR 65

Waschsystem I
Wash system I
Système de lavage I

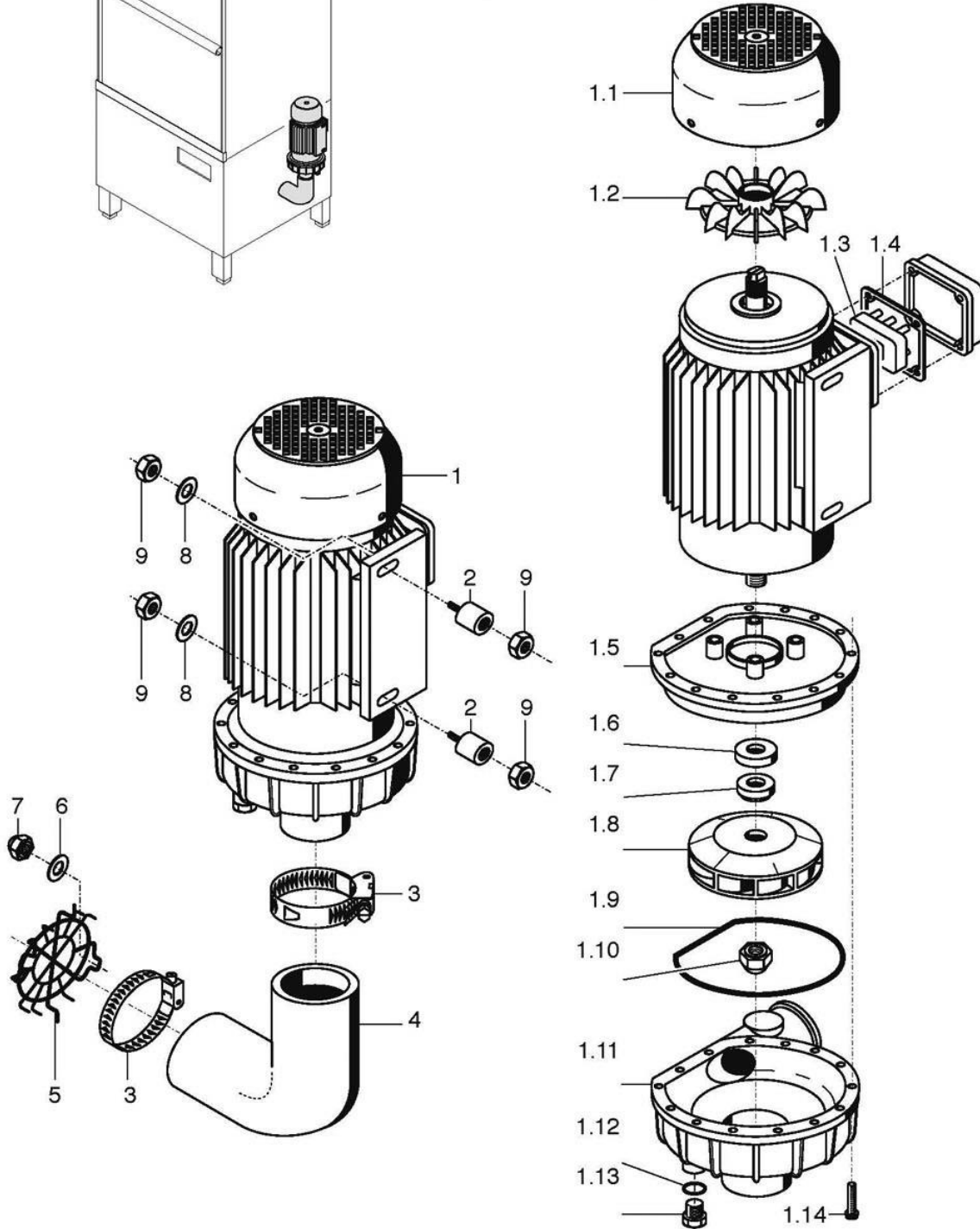
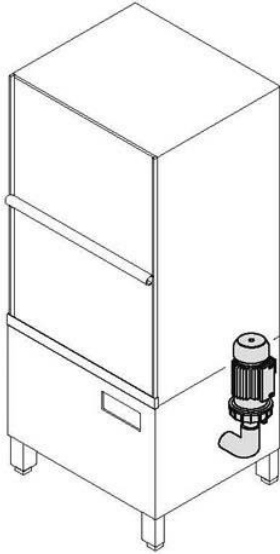

GR 64 / GR 65

Waschsystem II
Wash system II
Système de lavage II

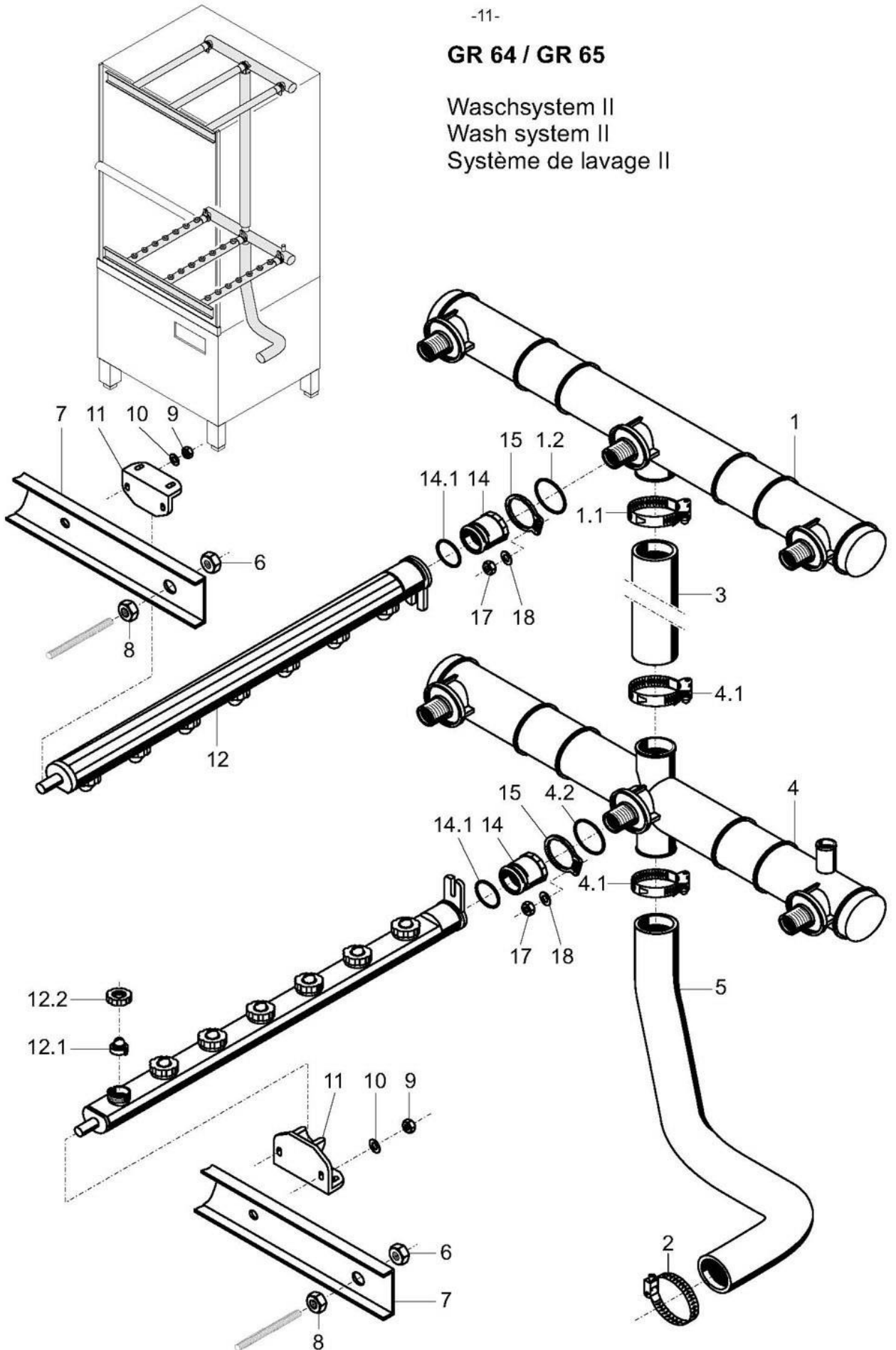

GR 64 / GR 65

Reversierung
Reversing
Reversé

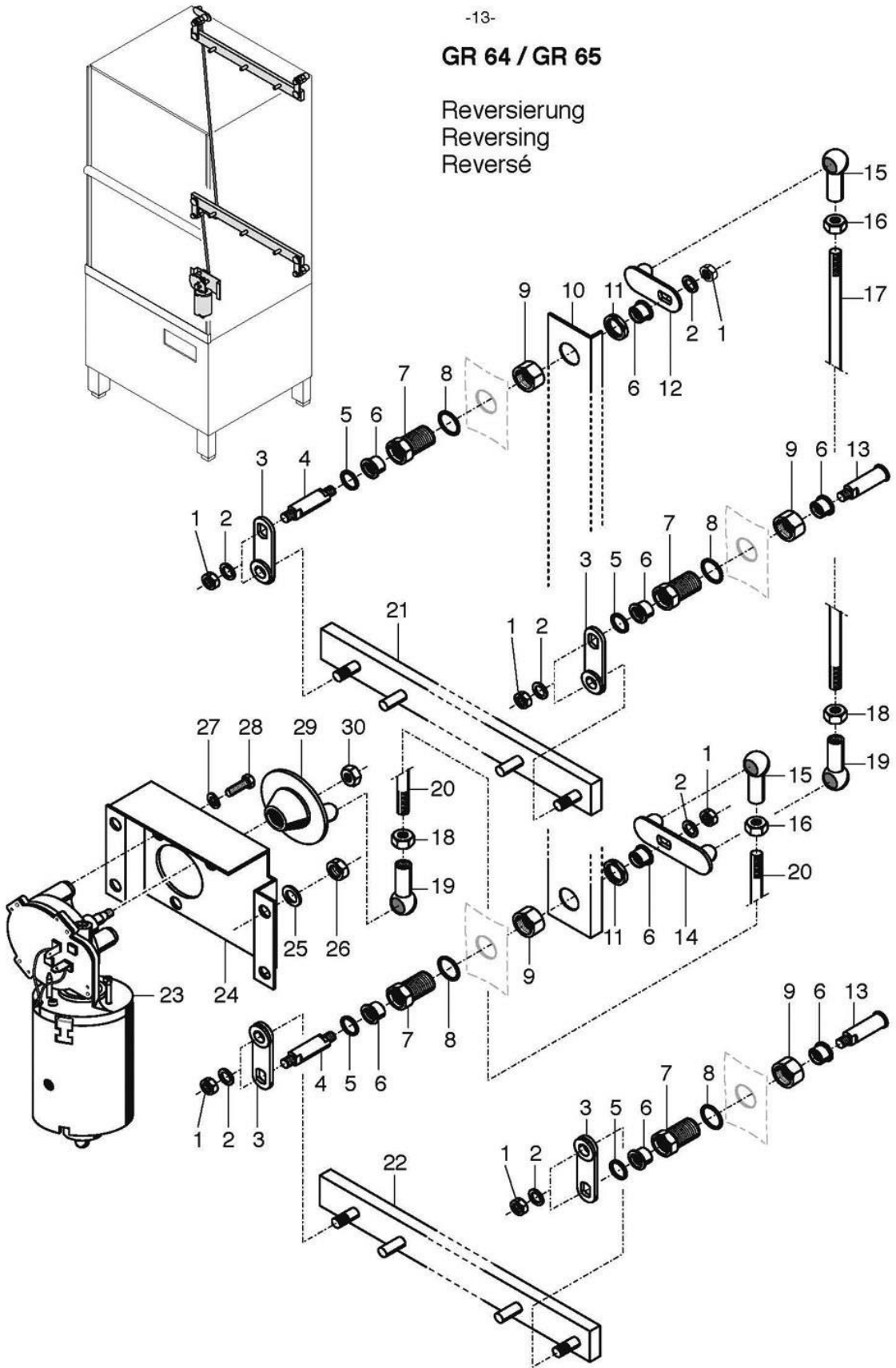

GR 64 / GR 65

Reversing

Item	Designation	Part No.	Pc.	Notes
1	Hex nut; M 6 self-locking	21 05 304		
2	Washer; \varnothing 6,4 x \varnothing 18 x 1,6	22 05 302		
3	Reversing lever	61006181	4	
4	Reversing shaft; \varnothing 12 x 66,6	60002385	2	
5	Rotary shaft seal; \varnothing 12 x \varnothing 22 x 4	27 10 021	4	
6	Plain bearing; \varnothing 12 x \varnothing 14 x 12	28 01 059	8	
7	Bearing bush; size 32 x 42,5	60002382	4	incl. O-ring 27 07 062
8	O-ring; 26 x 2,5	27 07 062	4	
	Seal; \varnothing 27 x \varnothing 34 x 2,0		4	replaced by 60002382
9	Lock nut; G 3/4" x 10; size 36	30 09 209	4	
10	Angel	65004323		GR 64
	Angel	65003002		GR 65
11	Lock nut narrow; G 3/4" x 5; size 32	61002626	2	
12	Lever	60002391		
13	Reversing axle; \varnothing 15 x 57,5	60002384	2	
14	Lever	65003803		
15	Ball cup; right	28 05 500	2	
16	Hex nut; M 8	21 01 305		
17	Threaded rod; \varnothing 8 x 775	65004047		GR 64
	Threaded rod; \varnothing 8 x 952	65003807		GR 65
18	Hex nut; M 8 LH	21 01 001		Left-handed thread
19	Ball cup; left	28 05 501	2	Left-handed thread
20	Threaded rod; \varnothing 8 x 180	65003806		
21	Connecting rod; top	65004132		
22	Connecting rod; bottom	65003987		
23	Geared motor; 24V; 6,0Nm	31 16 062		
24	Bracket	65004097		
25	Washer; \varnothing 5,3 x \varnothing 12,0 x 0,8	22 02 213		
26	Hex nut; M 5 self-locking	21 05 302		
27	Lock washer; B6	23 03 300		
28	Hex-head screw; M 6 x 10	20 01 332		
29	Ball plate	60001297		
30	Hex nut; M 8 self-locking	21 05 306		

GR 64 / GR 65

Nachspülung I
Rinsing I
Rinçage I

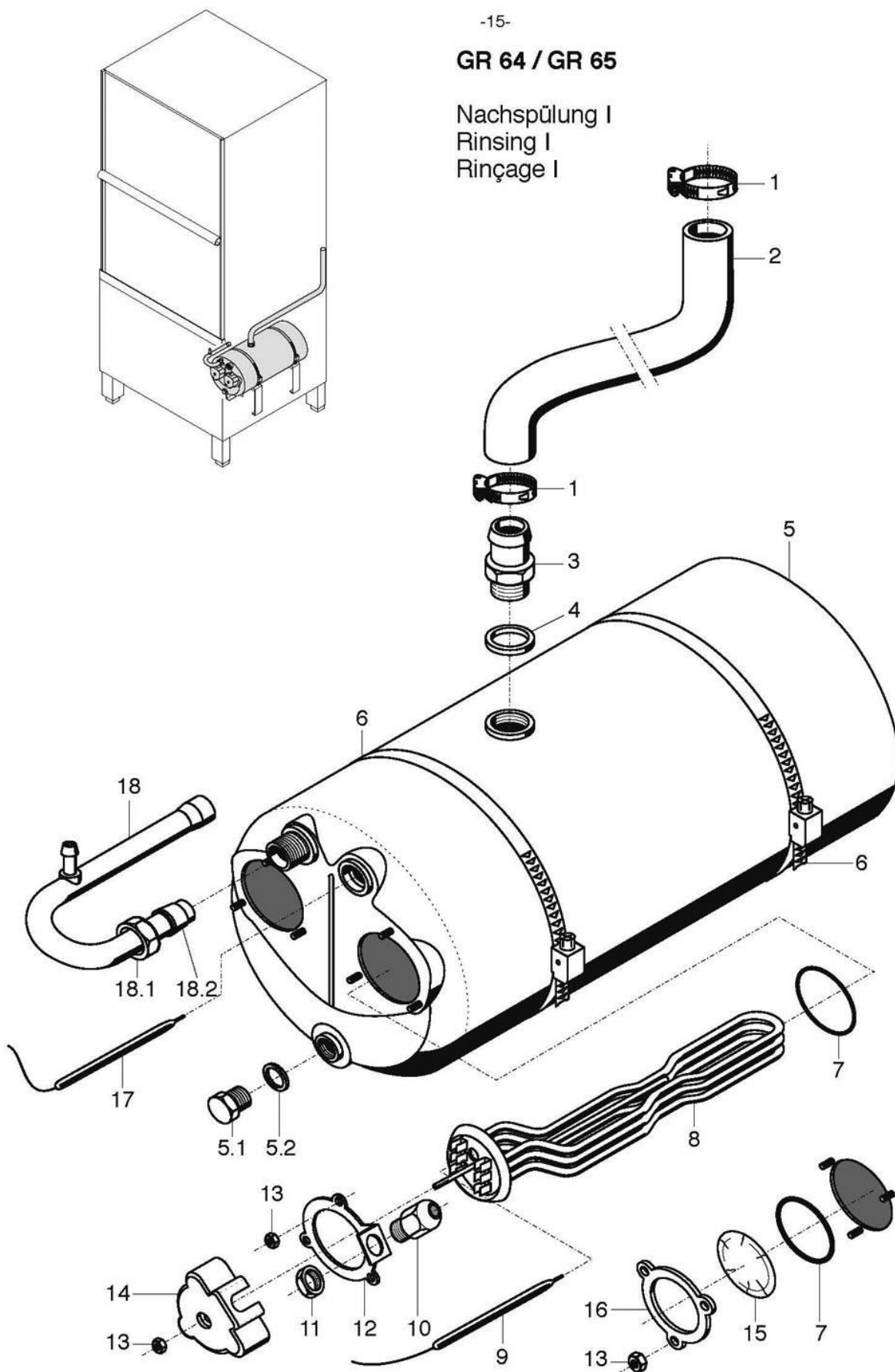

GR 64 / GR 65

Nachspülung II - AquaMatik
Rinsing II - AquaMatik
Rinçage II - AquaMatik

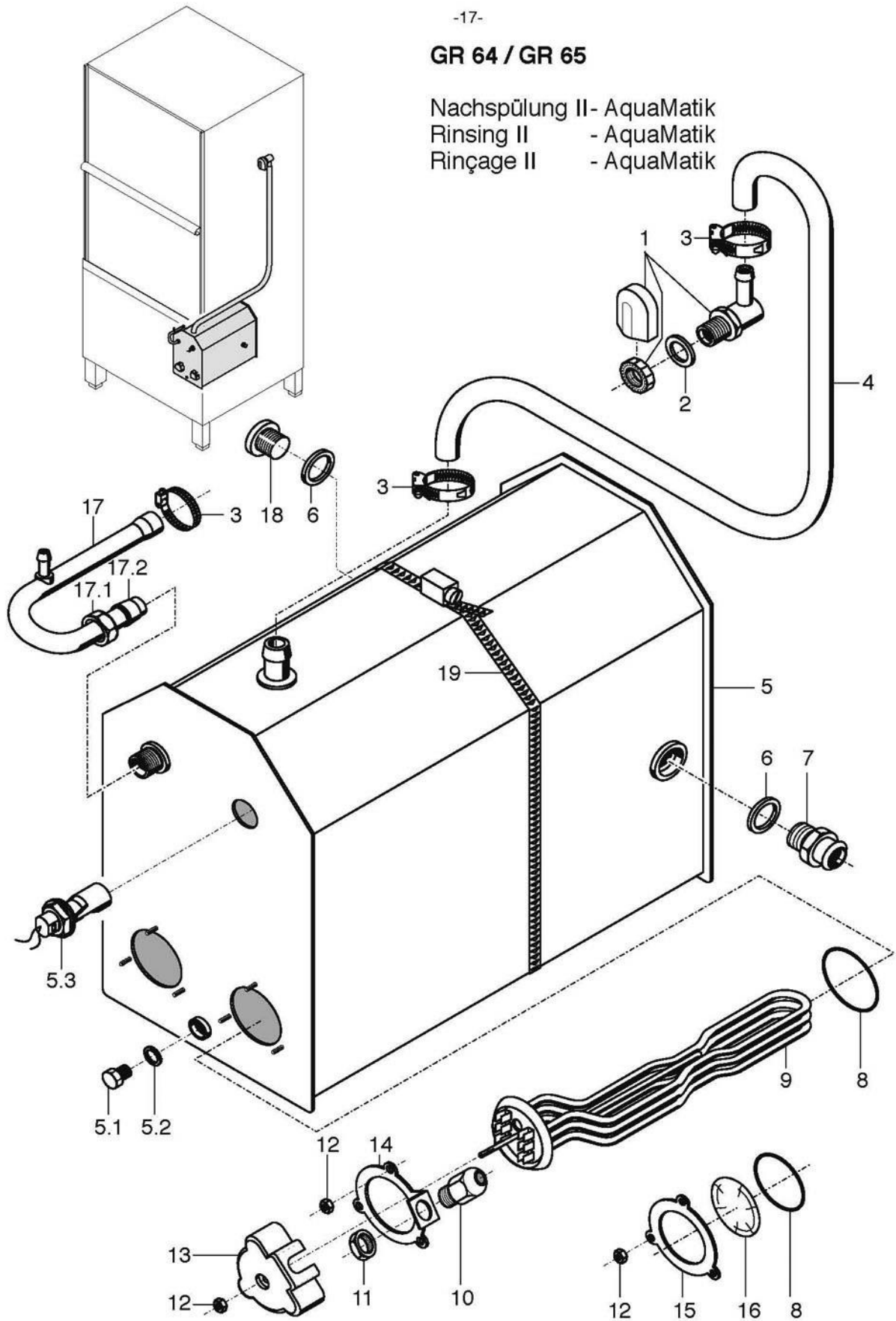

GR 64 / GR 65

Nachspülung III
Rinsing III
Rinçage III

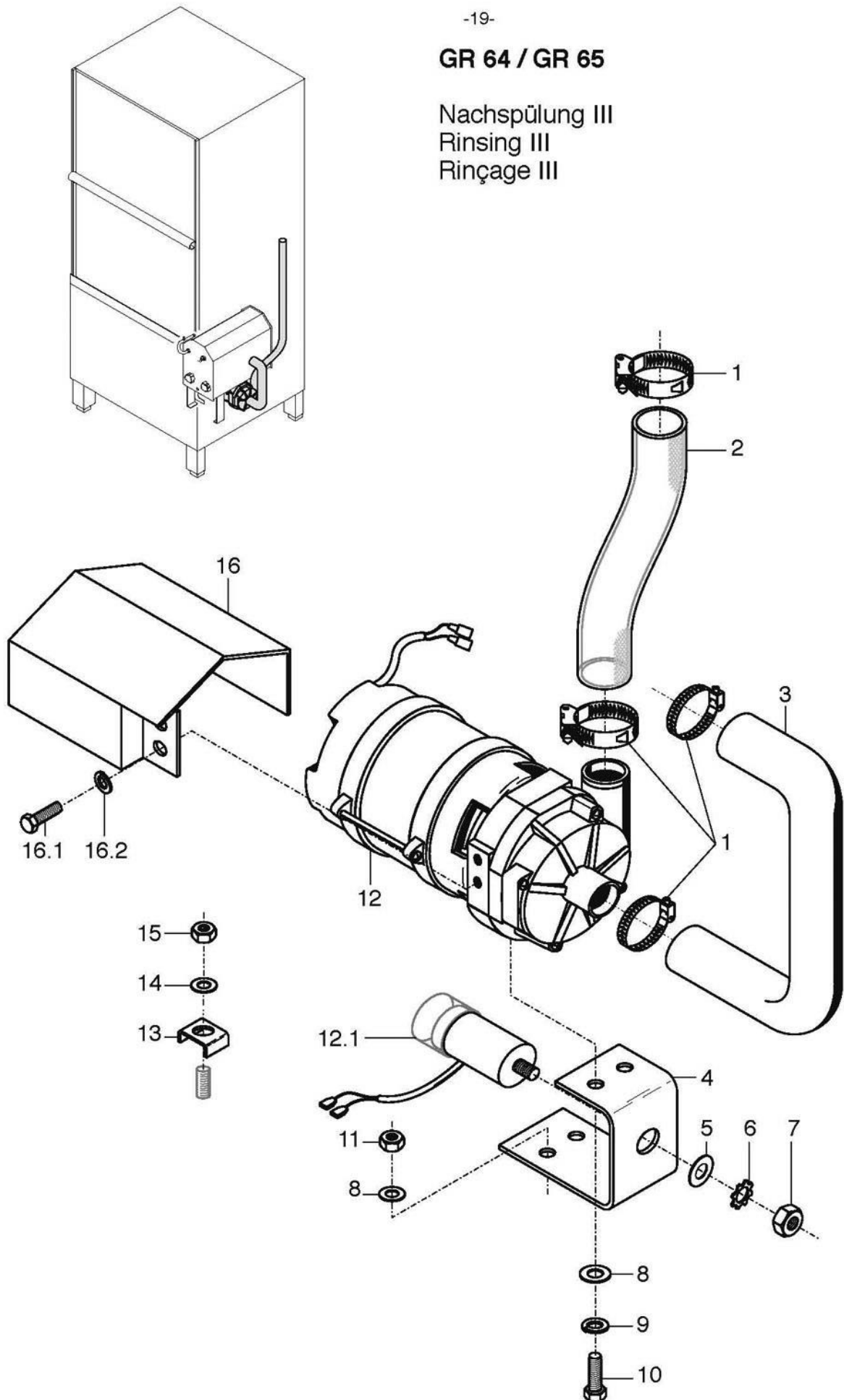

GR 64 / GR 65

Nachspülung IV
Rinsing IV
Rinçage IV

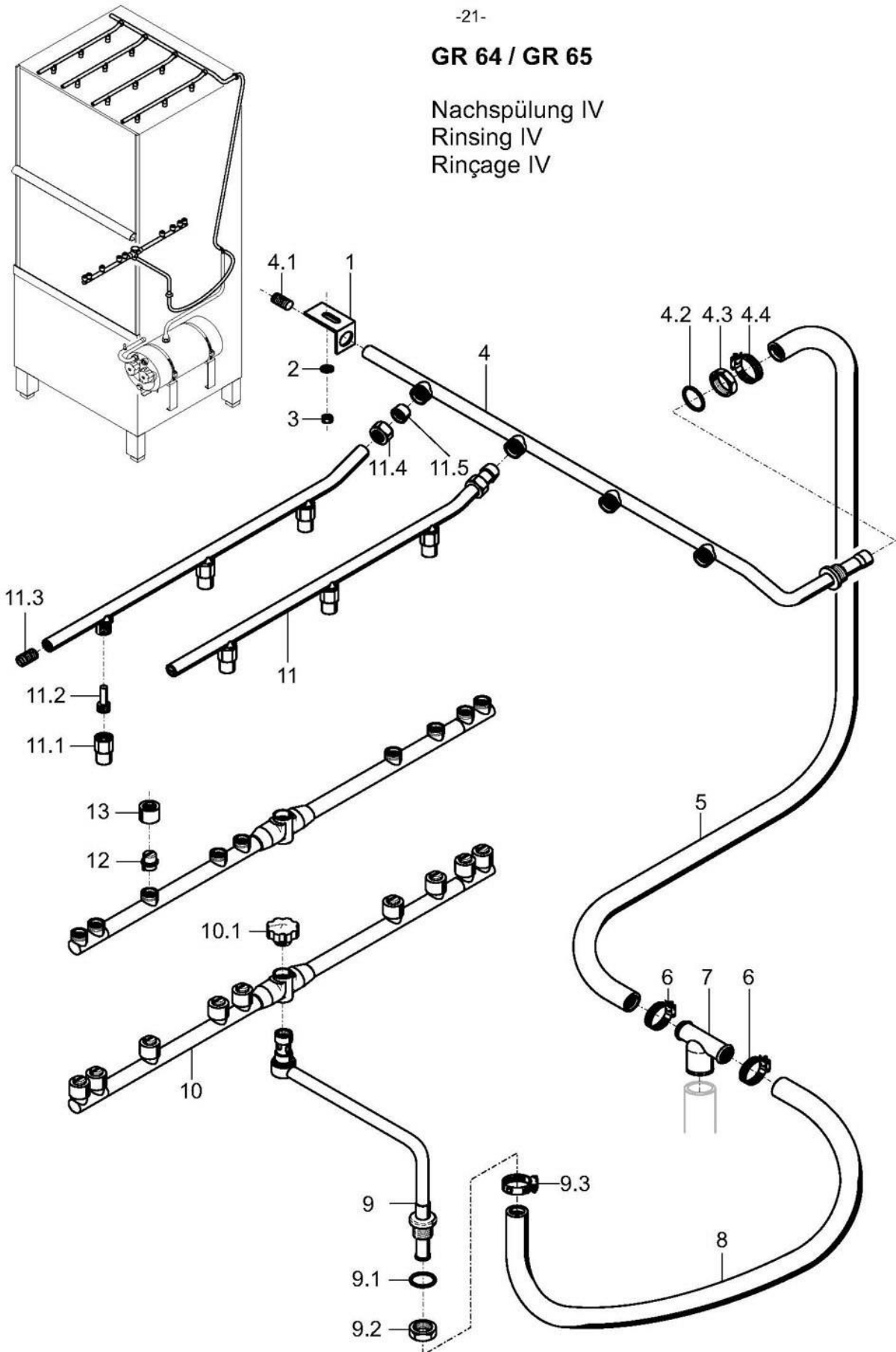

GR 64 / GR 65

Rinsing IV

Item	Designation	Part No.	Pc.	Notes
1	Angel	65003117		
2	Washer; \varnothing 5,3 x \varnothing 12 x 0,8	22 02 213		
3	Hex nut; M 5 self-locking	21 05 302		
4	Rinse manifold cpl.	65000032		incl. item 4.1 – 4.4
4.1	Grub screw; M 11 x 1 x 20	20 30 503		
4.2	O-ring; 16 x 2,5	27 07 001		
4.3	Lock nut; G 3/8"	30 09 200		
4.4	Hose clip; \varnothing 14 - \varnothing 24	28 02 108		
5	Hose; nom. dia. 12,5 x 4,5; 34,7 x 869,7	62001434		GR 64: adapt
6	Hose clip; \varnothing 14 - \varnothing 24	28 02 108		
7	Tee; \varnothing 25 x \varnothing 10	62001329		
8	Hose; nom. dia. 13 x 3,5 x 810	40 02 029		
9	Revolving arm support cpl.	65004811		incl. Pos. 9.1 – 9.3
9.1	O-ring; 20 x 3,5	27 07 040		
9.2	Hex nut; G 1/2" x 8; SW27	30 09 201		
9.3	Hose clip; \varnothing 14 - \varnothing 24	28 02 108		
10	Revolving arm cpl.	65005499		incl. item 10.1
10.1	Screw lid	61005681		
11	Rinse pipe top cpl.; 1 jet 30mm from beginning	65004011	2	incl. Pos. 11.1 - 11.5
	Rinse pipe top cpl.; 1 jet 120mm from beginning	65004012	2	
11.1	Nozzle cap; \varnothing 14,6 x 21	65002765	3	
11.2	Nozzle swirl device; \varnothing 8 x 18,8	65002764	3	
11.3	Grub screw; M 9 x 40	20 30 502		
11.4	Lock nut; G 3/8" x \varnothing 10,2	29 07 200		
11.5	Clamping ring; \varnothing 10,2	29 07 500		
12	Flat-jet nozzle; size 8	62002811	9	
13	Lock nut	62002812	9	

GR 64 / GR 65

Dosierung
Dosing
Dosage

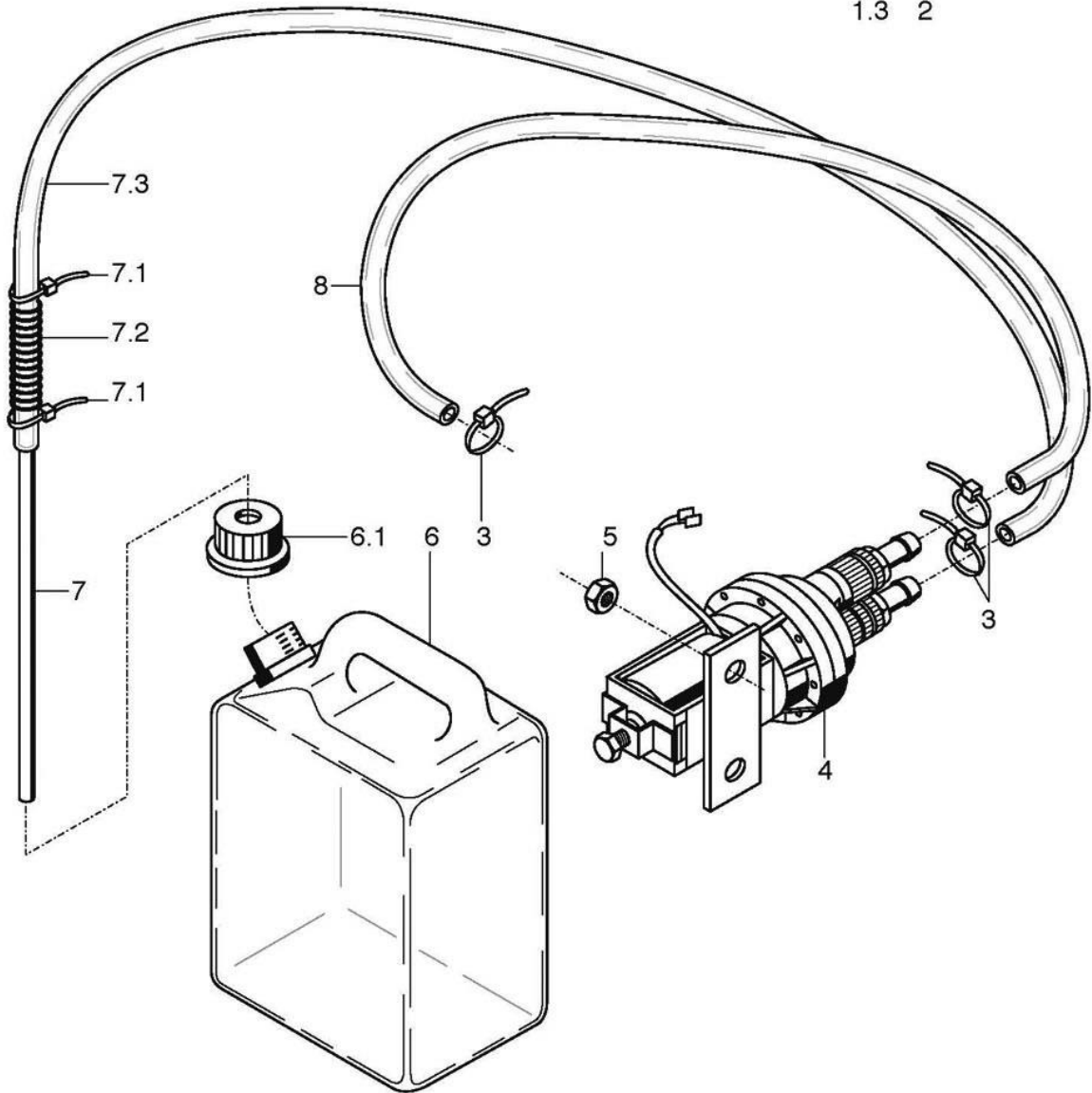
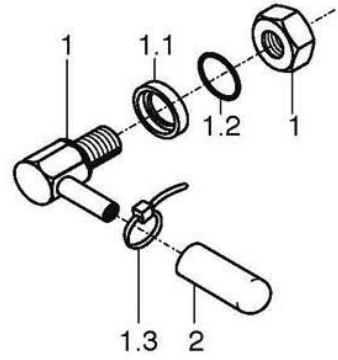
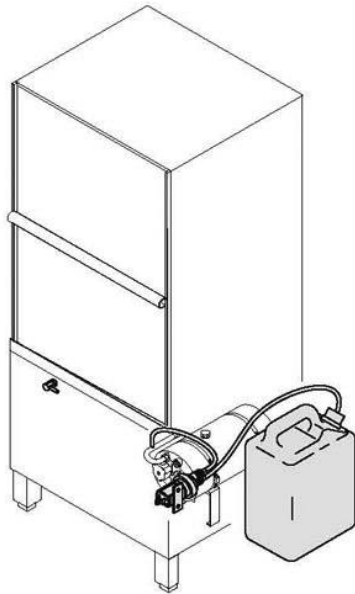

GR 64 / GR 65

Untergestell, Gehäuse und Verkleidung
Base frame, housing and panel
Châssis, boîte et habillage

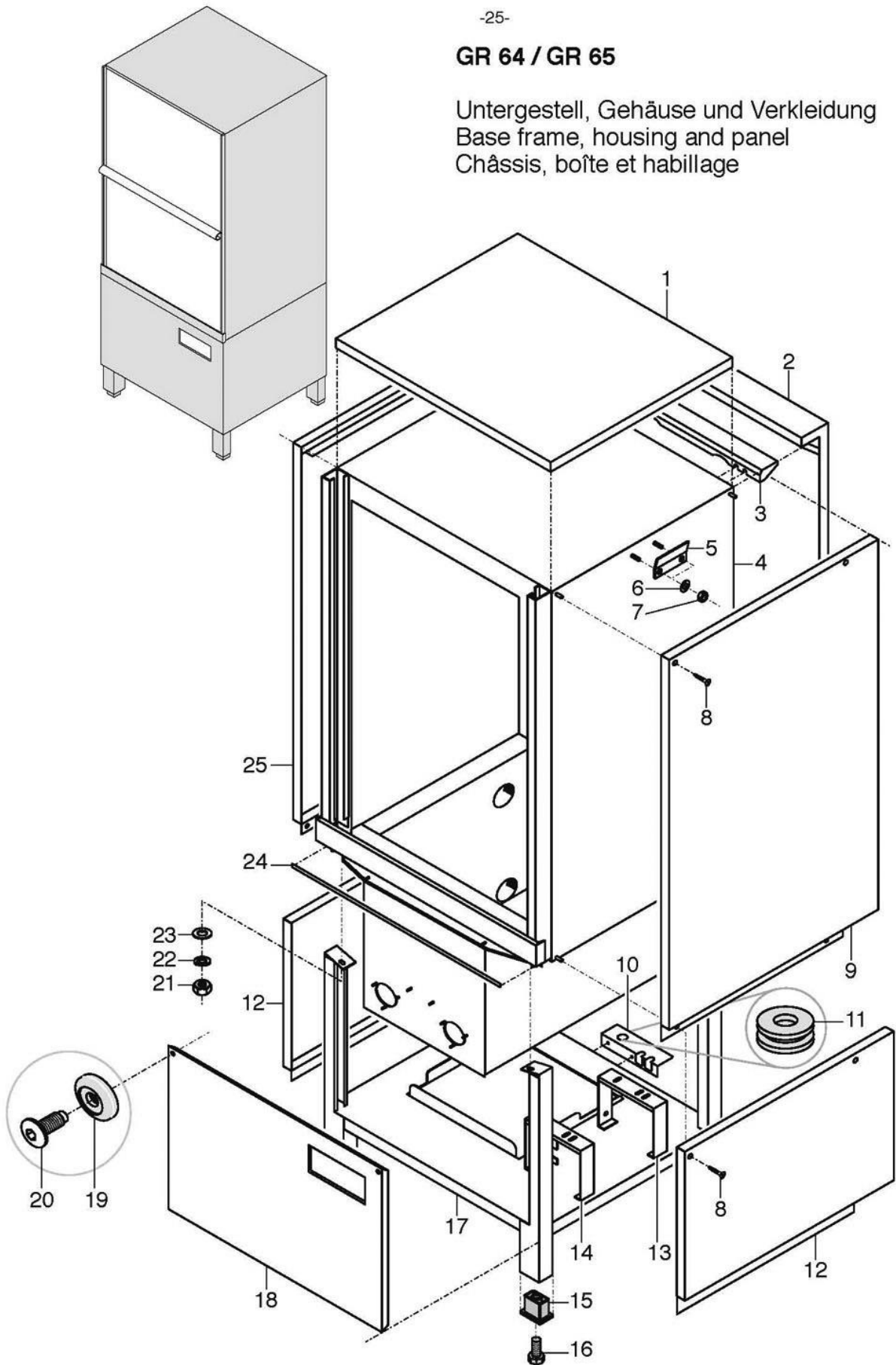

GR 64 / GR 65

Frame, container and panels

Item	Designation	Part No.	Pc.	Notes
1	Upper panel	65004646		
2	Rear panel	65004226		GR 64; up to mach.-no.: 390 224
	Rear panel	65004025		GR 65; up to mach.-no.: 390 224
	Rear panel	65004661		GR 64; from Masch.-no.: 390 225
	Rear panel	65004656		GR 65; from Masch.-no.: 390 225
3	Angel	65004742		
4	Housing; without door frame	65004029		GR 64; up to mach.-no.: 390 224
	Housing; without door frame	65004088		GR 65; up to mach.-no.: 390 224
	Housing; with door frame	65004685		GR 64; from mach.-no.: 390 225
	Housing; with door frame	65004684		GR 65; from mach.-no.: 390 225
5	Angel	65004187	2	up to mach.-no.: 390 224
6	Washer; \varnothing 5,3 x \varnothing 12 x 0,8	22 02 213		
7	Hex nut M 5	21 01 303		
8	Senkschraube; M 5 x 10	20 12 301		up to mach.-no.: 390 224
	Screw; M 5 x 15	70003736	8	from mach.-no.: 390 225
9	Upper panel	65004048		GR 64; up to mach.-no.: 390 224
	Upper panel	65004275		GR 65; up to mach.-no.: 390 224
	Upper panel right / left	65004650		GR 64; from mach.-no.: 390 225
	Upper panel right / left	65004610		GR 65; from mach.-no.: 390 225
10	Angel	65004657		from mach.-no.: 390 225
11	Nozzle	31 10 100		
12	Lower panel	65004273	2	up to mach.-no.: 390 224
	Lower panel	65004547	2	from mach.-no.: 390 225
13	Bracket	65004070		
14	Bracket	65004106		
15	Threaded insert; G 3/4"; 42 x 62 x 50	35 01 063	4	
16	Foot cleat; G 3/4"; 32 x 32 x 100	35 01 064	4	
17	Base	65004185		
18	Front panel	65004115		up to mach.-no.: 390 224
	Front panel	65004688		from mach.-no.: 390 225
19	Washer; \varnothing 7,2 x \varnothing 26 x 5,14	70003135	2	blue
20	Screw; M 5 x 15	70003736	2	
21	Hex nut; M 8	21 01 305		
22	Lock washer; B 8	23 03 301		
23	Washer; \varnothing 8,4 x \varnothing 16 x 1,6	22 01 303		
24	Gasket; 10 x 4 x 720	62001618		up to mach.-no.: 390 224
	Gasket; 716mm long; per metre	40 04 006		from mach.-no.: 390 225
25	Upper panel	65004048		GR 64; up to mach.-no.: 390 224
	Upper panel	65004275		GR 65; up to mach.-no.: 390 224
	Upper panel right / left	65004650		GR 64; from mach.-no.: 390 225
	Upper panel right / left	65004610		GR 65; from mach.-no.: 390 225
n.p.	Silicone glue; Elastosil E43	34 03 012		for gasket

GR 64 / GR 65

Tür
Door
Porte

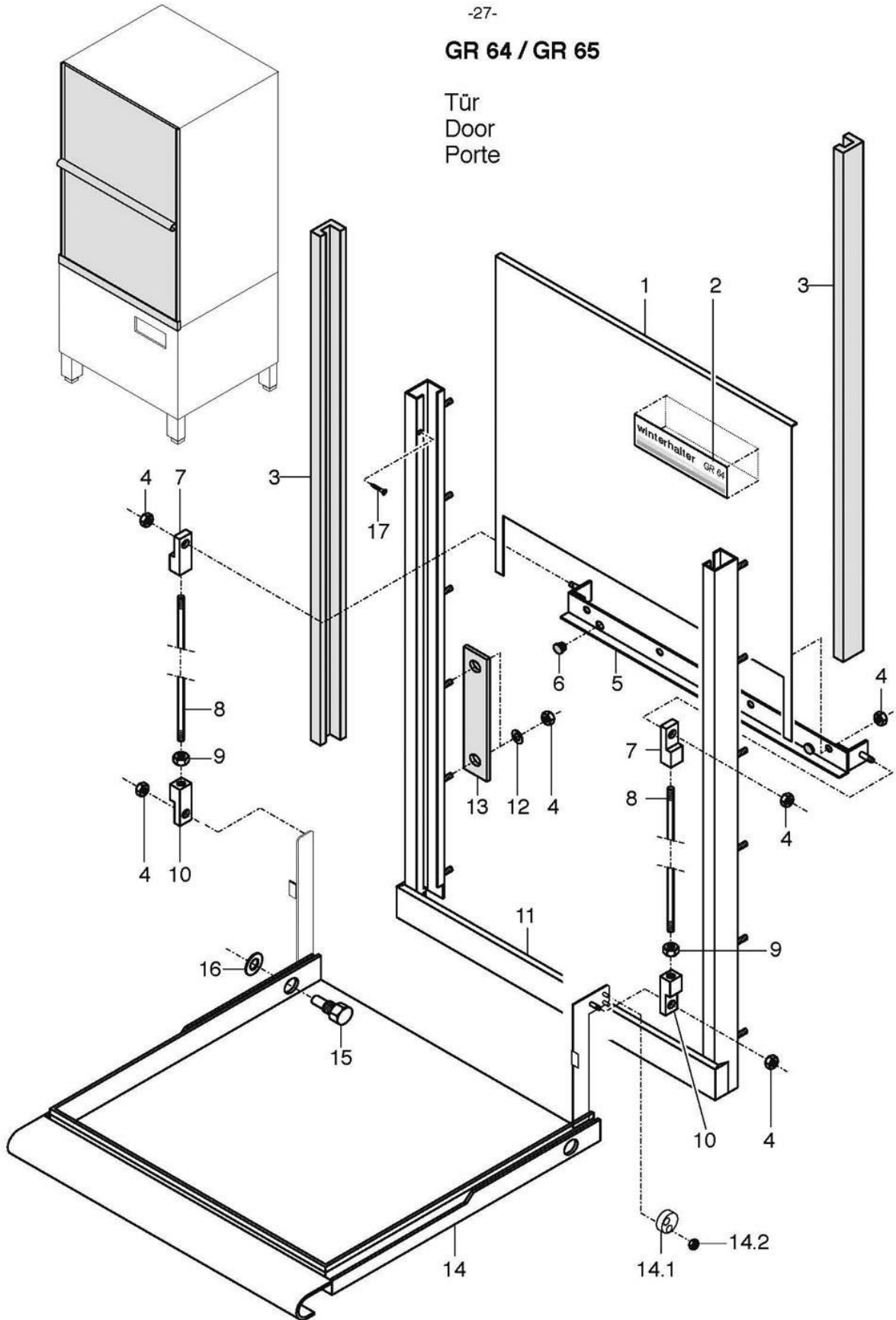

GR 64 / GR 65

Door

Item	Designation	Part No.	Pc.	Notes
1	Lifting door	65004042		GR 64; up to mach.-no.: 390 224
	Lifting door	65003967		GR 65; up to mach.-no.: 390 224
	Lifting door	65004491		GR 64; from mach.-no.: 390 225
	Lifting door	65004488		GR 65; from mach.-no.: 390 225
2	Sign; "Winterhalter GR 64"	65004312		
	Sign; "Winterhalter GR 65"	65004311		
3	Guide profile; 31,5 x 38,5 x 722	65004054	2	GR 64; up to mach.-no.: 390 224
	Guide profile; 31,5 x 38,5 x 892	65003978	2	GR 65; up to mach.-no.: 390 224
	Guide profile; 33,75 x 39 x 745	65004668	2	GR 64; from mach.-no.: 390 225
	Guide profile; 33,75 x 39 x 915	65004448	2	GR 65; from mach.-no.: 390 225
4	Hex nut; M 6 self-locking	21 05 304	30	
5	Hanging rail	65003970		
6	Pushbutton buffer; \varnothing 13 x 8,5	40 06 015	2	
7	Adjusting knob; left-threaded	65001617	2	
8	Door push rod; \varnothing 8 x 375	65004216	2	GR 64
	Door push rod; \varnothing 8 x 504	65004184	2	GR 65
9	Hex nut; M 8	21 01 305		
10	Adjusting knob; right-threaded	65001616	2	
11	Door frame	65004032		GR 64; up to mach.-Nr.: 390 224
	Door frame	65003930		GR 65; up to mach.-Nr.: 390 224
12	Washer; \varnothing 6,4 x \varnothing 12 x 1,6	22 01 302		
13	Stop rail; 20 x 2,5 x 123	65003947	2	up to mach.-Nr.: 390 225
14	Folding door	65004037		GR 64; incl. item 14.1, 14.2
	Folding door	65003963		GR 65; incl. item 14.1, 14.2
14.1	Kit Magnetholder	55 28 291		incl. magnet
14.2	Hex nut; M 5 self-locking	21 05 302		
15	Bearing bolt; SW15 x 26	65001537	2	
16	Washer; \varnothing 8,4 x \varnothing 17 x 1,6	22 01 303		
17	Sheet-metal screw; B 2,9 x 9,5	20 21 301		up to mach.-no.: 390 224
	Sheet-metal screw; B 2,9 x 8,5	20 20 309		from mach.-no.: 390 225

GR 64 / GR 65

Elektroteile I
Electrical parts I
Matériel électrique I

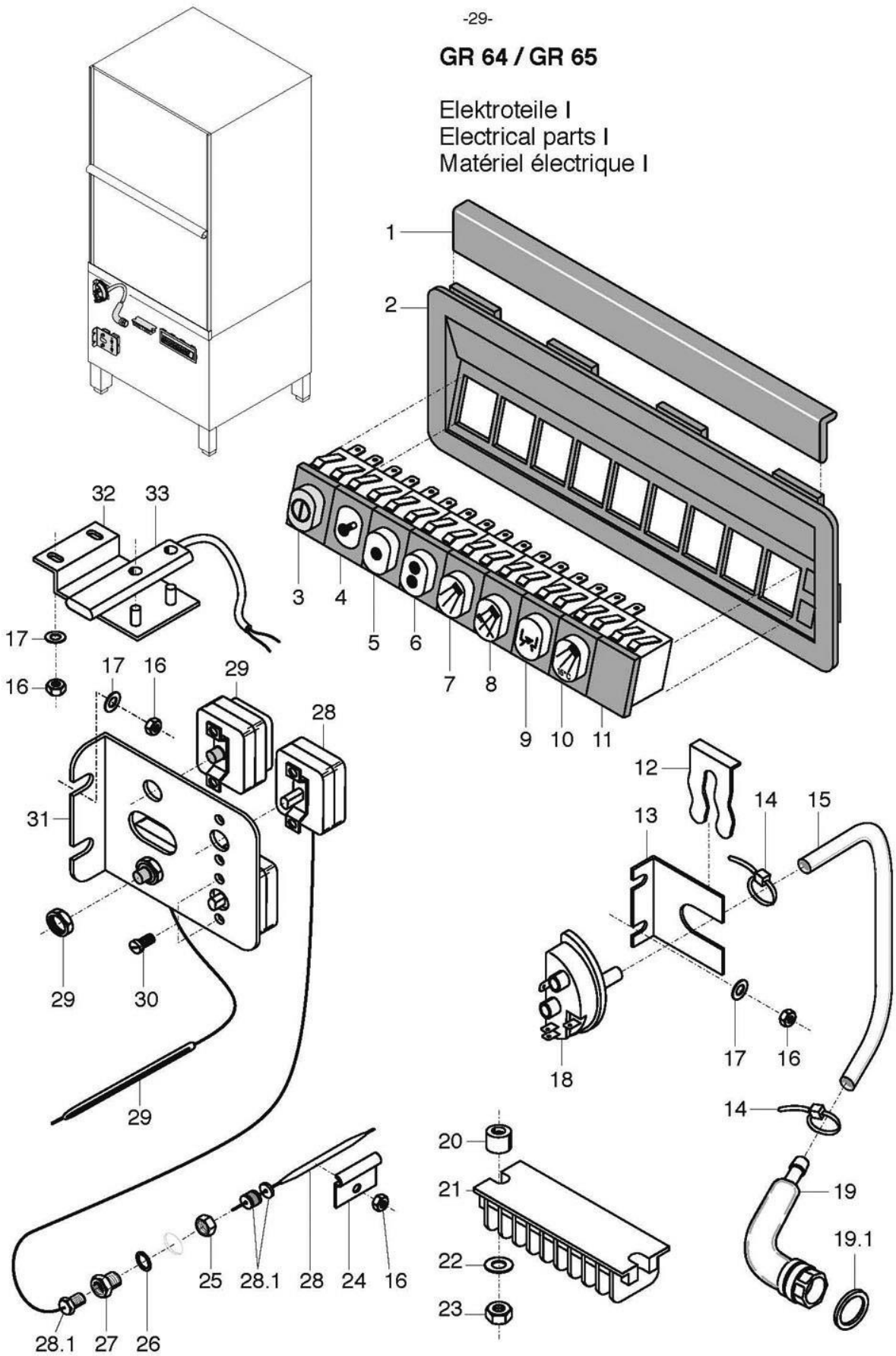

GR 64 / GR 65

Electrical parts I

Item	Designation	Part No.	Pc.	Notes
1	Clamping profile	61004234		
2	Switch panel	61004233		
3	Push button; "S"; green; 250V AC	31 24 186		ON / OFF
4	Lamp; white; 220V	31 08 116		HEATING
5	Push button; white	31 24 153		PROGRAMME I
6	Push button; white	31 24 130		PROGRAMME II
7	Push button; white	31 24 205		WASH MANUAL
8	Push button; white	31 24 129		RINSE
9	Push button; white	31 24 202		DRAIN VALVE
10	Push button; white	31 24 197		PRERINSE COLD (Option)
11	Filler piece	31 24 187		
12	Clamping spring for level controller	31 26 001		
13	Level controller holder	61002345		
14	Cable binder; 162 x 2,5	31 20 014		
15	Hose; nom. dia. 5 x 1,5 x 280	40 01 024		per metre
16	Hex nut; M 5 self-locking	21 05 302		
17	Washer; \varnothing 5,3 x \varnothing 12 x 0,8	22 02 213		
18	Level controller; 160/80	80003155		
19	Air chamber cpl.	55 04 024		incl. item 19.1
19.1	Seal; \varnothing 26 x \varnothing 36 x 2,0	27 01 003		
20	Spacer roller; \varnothing 5,3 x \varnothing 12 x 7	22 08 513	2	
21	Terminal strip	31 09 155		
22	Washer; \varnothing 5,3 x \varnothing 10 x 1,0	22 01 300		
23	Hex nut; M 4 self-locking	21 05 300		
24	Thermostat clip	55 19 011		
25	Hex nut; M 14 x 1 x 5	31 25 002		
26	Seal; \varnothing 14,2 x \varnothing 20 x 2,0	27 09 036		
27	Stuffing box forthermostat; M 14 x 1; size 19 x 15	31 25 001		
28	Thermostat; 1750mm long; 220V	31 25 013	2	incl. item 28.1
28.1	Stuffing box gland	31 25 012		
29	Safety thermostat; 140°C - 10K "OFF"	31 25 030	2	with nut
30	Pan-head screw; M 4 x 6	20 10 309		
31	Thermostat holder	65002459		
n.p.	Thermostat sign; red with arrow	28 03 322		
n.p.	Sign "Boiler"	28 03 107		
n.p.	Sign "Tank"	28 03 108		
32	Bracket	65003234		
33	Magnetic switch; 180-265V; 50/60Hz	31 24 221		

GR 64 / GR 65

Elektroteile II
Electrical parts II
Matériel électrique II

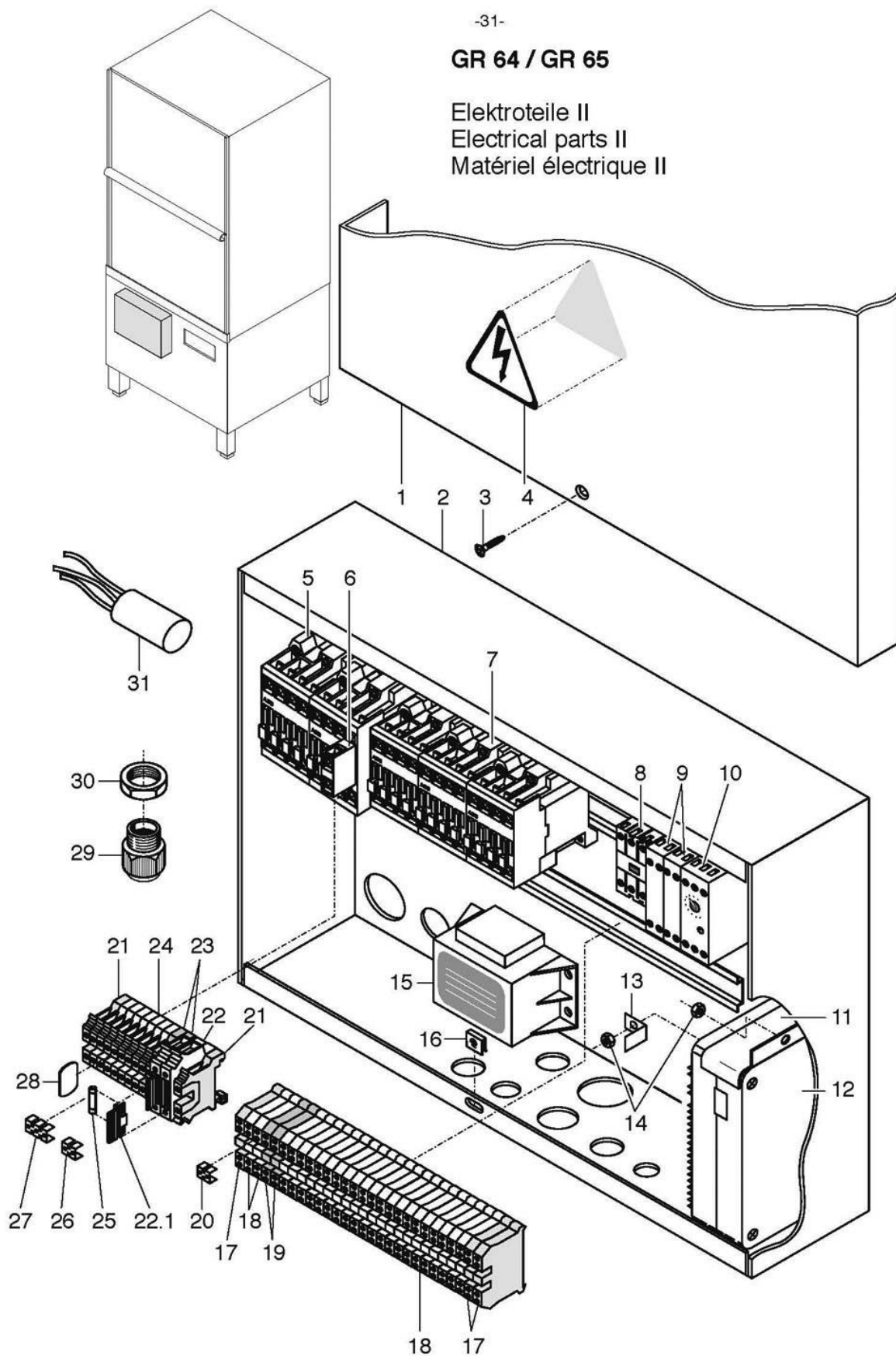

GR 64 / GR 65

Electrical parts II

Item	Designation	Part No.	Pc.	Notes
1	Switch box cover	65004117		
2	Switch box housing	65004114		
3	Sheet-metal screw; B 3,9 x 13	20 20 310		
4	Sign "Arrow"	28 03 009		
5	Contactora; 220-255 V; 50/60 Hz; A 30	31 04 165	2	Boiler 12kW
	Contactora; 200-220 V; 50/60 Hz; A 30	31 04 164	2	Japan; Boiler 9kW
6	Auxiliary switch; make contact	31 04 166		
7	Contactora; 220-255 V; 50/60 Hz; A 16	31 04 162	5	
	Contactora; 200-220 V; 50/60 Hz; A 16	31 04 163	6	Japan
8	Contactora relay; 220-240 V; 50/60 Hz; CA2-SK11	31 04 114		
9	Coupling relay; 180-254V AC; 2A	31 04 139	2	drain solenoid valve
10	Intervall time-delay relay; 220-240V AC; 15 - 300s	31 04 150		
11	Programme switch bracket	61003088		
12	Programme switch; EPS 1.1; 230V; 50/60Hz	31 05 131		
	Programme switch; EPS 1.1; 200V und 240V; 50/60 Hz	31 05 132		
13	Angle	65003612		
14	Hex nut; M 5 self-locking	21 05 302		
15	Safety transformer; 230V AC / 18V DC	31 15 020		
16	Sheet-metal nut; B 3,5	21 17 002		
17	Double terminal; green/yellow; UDK 4 - PE	31 09 153	3	
18	Double terminal; grey; UDK 4	31 09 151	24	
19	Double terminal; blue; UDK 4	31 09 152	2	
20	Fixed bridge; 2-pole; FB 2-6	31 09 126	2	
n.p.	Isolating disk	31 09 169		
21	Universal terminal green/yellow; USLKG 10	31 09 059	2	
22	Universal-Fuseterminal UK-SI	31 09 063	2	incl. item 22.1
22.1	Fused plug	31 09 072	2	
23	Universal terminal blue; UK 10	31 09 058	2	
24	Universal terminal grey; UK 10	31 09 057	7	
25	Fuse; 250V; 6,3A	31 11 043	4	
26	Fixed bridge; 2-pole; FB 10-8	31 09 128	3	
27	Fixed bridge; 3-pole; FB 10-8	31 09 138		
28	Isolating disk; TS-K	31 09 066	3	
29	Cable gland; PG 29 with strain relief device	31 10 123		
	Cable gland; PG 21 with strain relief device	31 10 070	3	
	Cable gland; PG 16 with strain relief device	31 10 049		
	Cable gland; PG 11 with strain relief device	31 10 044		
o.p.	Locking screw; PG 16	31 10 025	2	
	Locking screw; PG 9	31 10 021		
30	Hex nut; PG 29	31 10 047	2	
	Hex nut; PG 21	31 10 071	2	
	Hex nut; PG 16	31 10 110	3	
	Hex nut; PG 11	31 10 045		
	Hex nut; PG 9	31 10 043		
31	Interference supression capacitor; 0,27MF + 2 X 27000PF	31 13 078		
n.p.	Reducing ring; KUK 29/21	31 10 091		
n.p.	Power supply cable; 5 x 2,5mm ² x 4000	31 23 138		
n.p.	Cable harness; heating / pump	65004124		
n.p.	Cable harness; solenoid valve	65004125		Drain solenoid valve
n.p.	Cable harness; control	65004126		
n.p.	Cable harness; switch panel	65004121		

GR 64 / GR 65

Cold water pre-rinsing (option)

Item	Designation	Part No.	Pc.	Notes
1	Water inlet set (incl. item 2)	61004545		up to mach.-no.: 390 224
	Water inlet set (incl. seal)	55 31 007		from mach.-no.: 390 225
2	Seal; \varnothing 17 x \varnothing 24 x 2,0	62001366		
3	Hose clip; \varnothing 14 - \varnothing 24	28 02 108		
4	Shaped hose; nom. dia. 13 x 4	40 03 053		from mach.-no.: 390 225
5	Backflow restrictor; lateral	35 01 194		up to mach.-no.: 390 224
	Backflow restrictor; top	35 01 193		from mach.-no.: 390 225
6	Hose; nom. dia. 13,5 x 3,5 x 55	40 02 029		per metre
7	Cap nut; G 3/4" x \varnothing 20; size 30 x 14	29 07 203		
8	Hose connecting piece; R 3/4" x 1/2"	29 06 222		
9	Seal; \varnothing 14,2 x \varnothing 22,5 x 1,5	27 09 007		
10	Backflow restrictor; DW 20	29 01 512		
11	Double nipple; G 3/4" x 26; size 27	30 11 207		
12	Hose; nom. dia. 13,5 x 3,5 x 55	40 02 029		GR 64; per metre
	Hose; nom. dia. 13,5 x 3,5 x 225	40 02 029		GR 65; per metre
13	Hose connection tee; \varnothing 13	29 06 508		
14	Hose; nom. dia. 13,5 x 3,5 x 310	40 02 029		per metre
15	Hose; nom. dia. 13,5 x 3,5 x 650	40 02 029		per metre
16	Shaped hose; nom. dia. 13 x 4	62001434		adapt
17	Backflow restrictor; top	35 01 193	2	
18	Hose; nom. dia. 13,5 x 3,5 x 45	40 02 029		per metre
19	T-piece; \varnothing 25 x \varnothing 10	62001329		
20	Hose; nom. dia. 13,5 x 3,5 x 810	40 02 029		per metre
21	Hose clip; \varnothing 24 - \varnothing 44	28 02 309		
22	Hose elbow; nom. dia. 25 x 4,0	65004182		
	Fabric hose; nom. dia. 25 x 4,5 x 900	40 01 023		in case of AquaMatik
23	Hose; nom. dia. 13,5 x 3,5 x 2030	40 02 029		GR 64; per metre
	Hose; nom. dia. 13,5 x 3,5 x 2200	40 02 029		GR 65; per metre
24	Solenoid valve; 220-240V; 50/60Hz	31 06 187		
	Solenoid valve; 180-220V; 50/60Hz	31 06 199		
25	Washer; \varnothing 4,3 x \varnothing 12,0 x 1,0	22 05 300		
26	Pan-head screw; M 4 x 8	20 10 210		
27	Dirt strainer	31 06 186		
28	Metal hose; nom. dia. 15 x 1500; G 3/4"	29 01 303		incl. item 28.1
28.1	Seal; \varnothing 16 x \varnothing 24 x 3,0	80002241	2	
29	Dirt trap cpl.	80002153		incl. items 29.1 - 29.3
29.1	Double nipple; G 3/4" x 40; size 30	80002167		
29.2	Seal; \varnothing 16 x \varnothing 24 x 3,0	80002241	2	
29.3	Dirt trap	80002728		